

RHIMEX.com

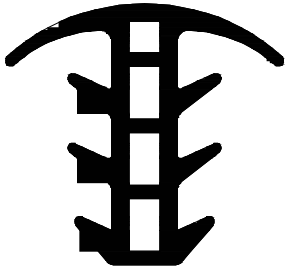

Profiles of rubber, sponge rubber,
silicone, foam silicone

T-Profiles

TP

Solid rubber

Legend

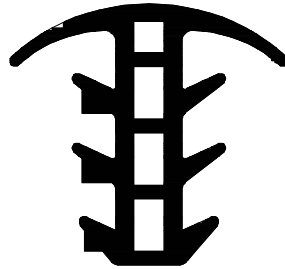

9999

means

Profile-No.

EP / s / 9999

means

Quality / Colour / Article-No.

Quality

CR	Neoprene
EP	EPDM
NBR	Perbunan
NK	Natural rubber
Si	Silicone
SPS	Foam silicone
FPM	VITON [®]
PVC	Soft-PVC
EVA	Ethylenvinylacetat
SBR	Buna (Styrol-Butadien)
TPE	Thermoplast. Elastomer

Colours

s	black
g	grey
w	white
az	anthracite
bg	beige
br	brown
hg	light-grey
rb	red-brown
t	translucent
r	red
x	colour selectable

® = Entered registered trade mark of the company DuPont

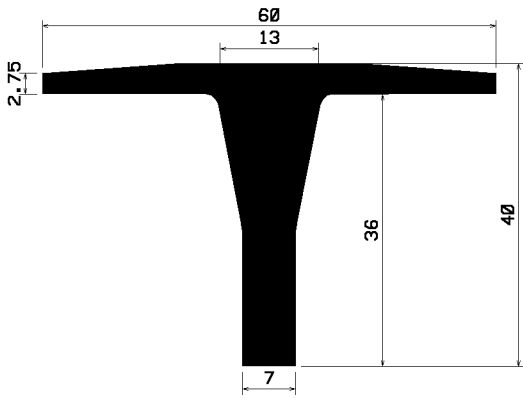

235
EP/s/ 2035

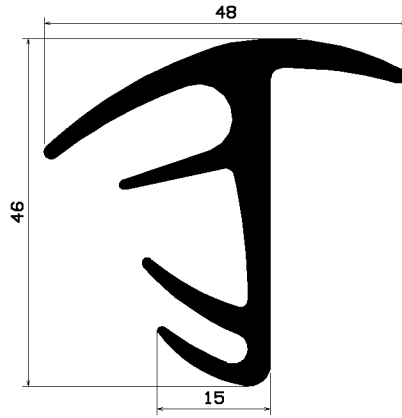

271
EP/s/ 2593

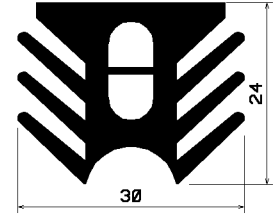

398
EP/s/ 2721



461
EP/s/ 7105

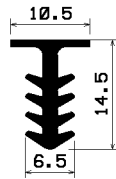

491
EP/s/ 2885

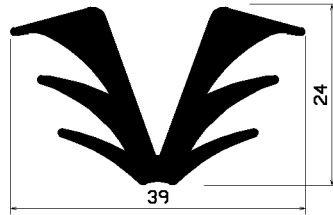

537
EP/s/ 2877

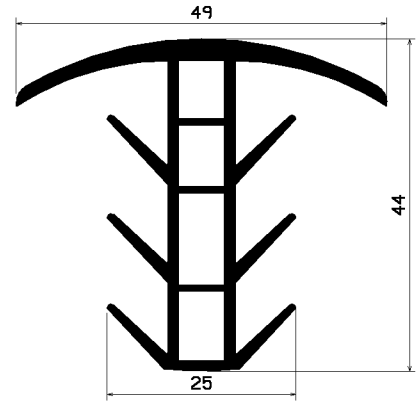

636
TPE/s/ 3383
EP/s/ 7858

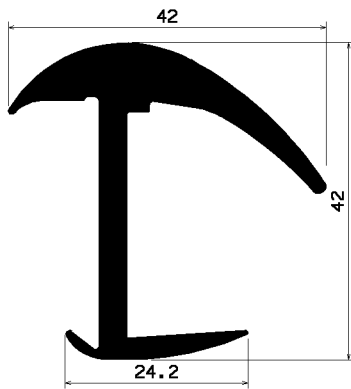

740
EP/s/ 2124

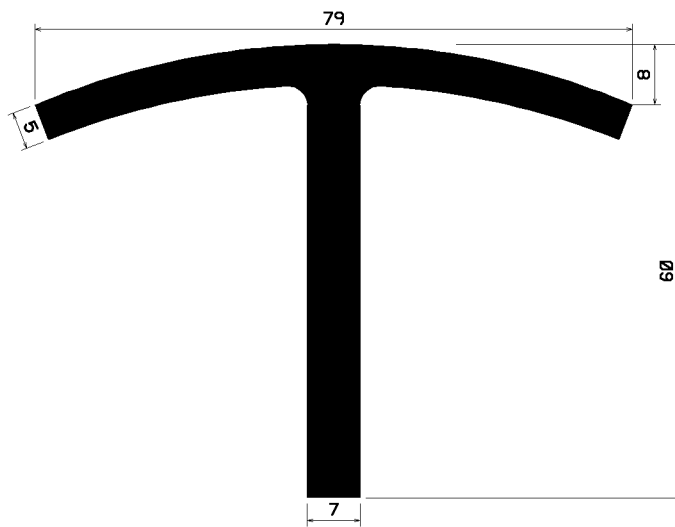

742
EP/s/ 2175

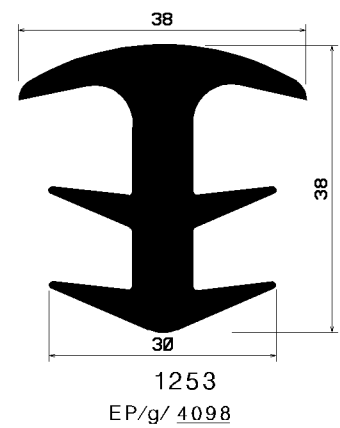
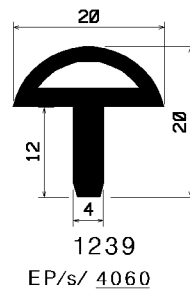
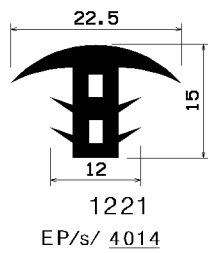
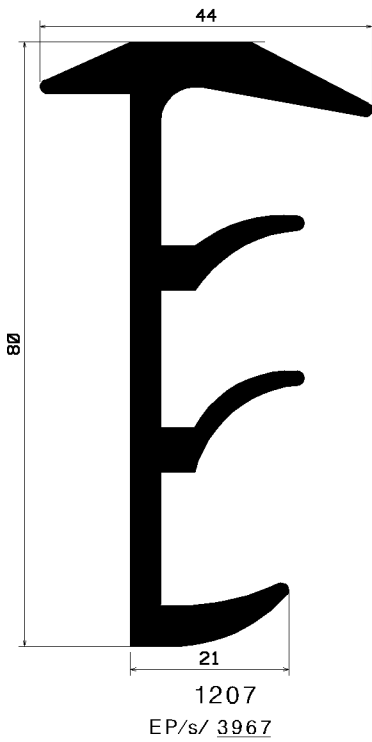
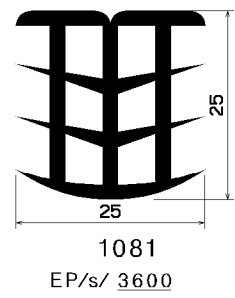
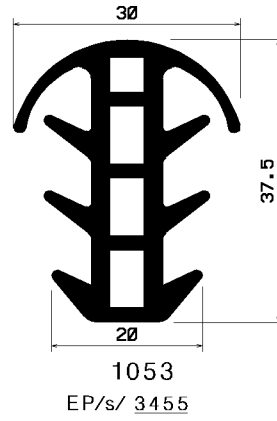
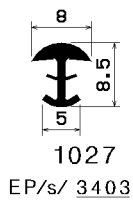
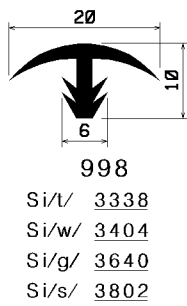
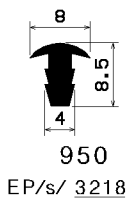
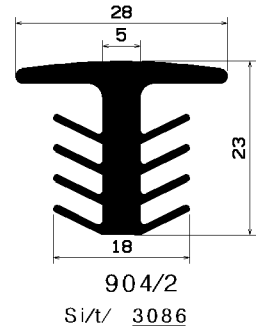
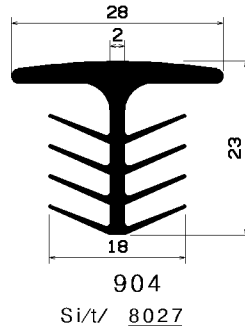
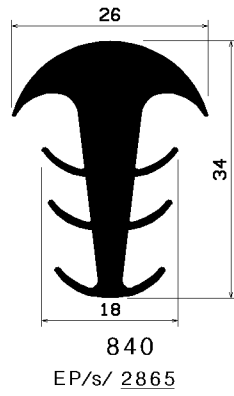
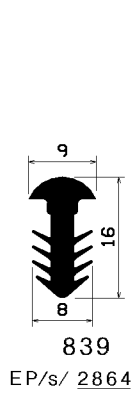
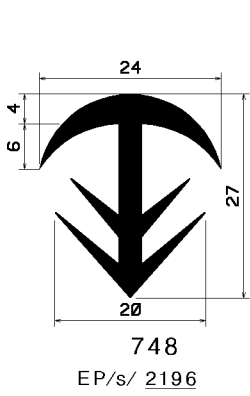

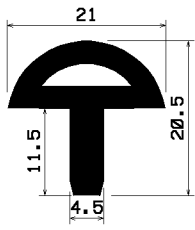

1267
EP/s/ 4142

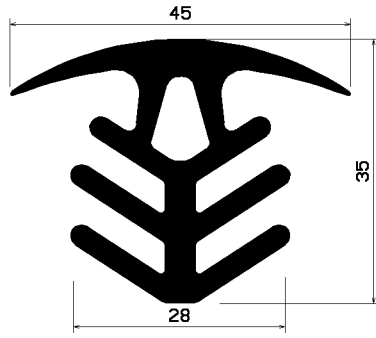

1349
EP/g/ 1191

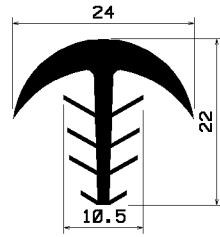

1437
CR/s/ 3480

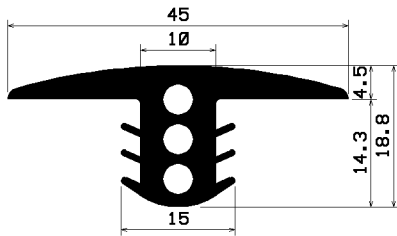

1457
PVC/or/4536
PVC/bl/4537
NBR/s/ 6799

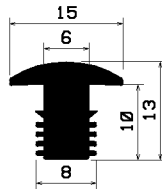

1471
EP/s/ 4603

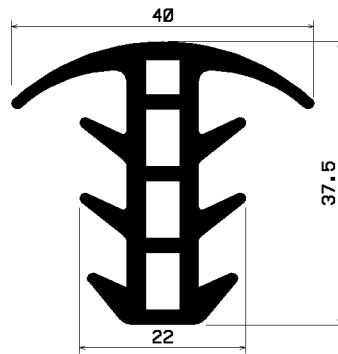

1479
EP/s/ 4700

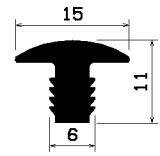

1486
EP/s/ 4666

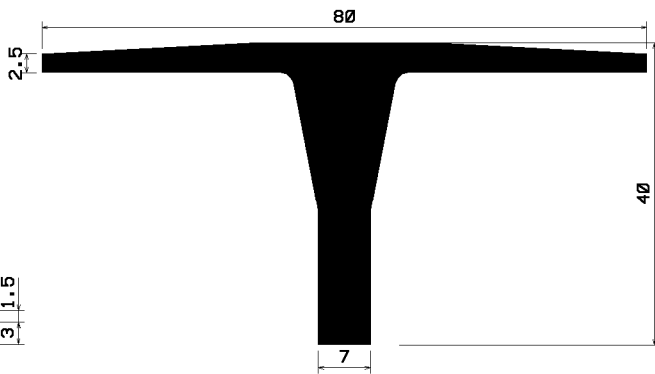

1550
EP/s/ 4773

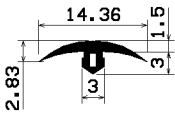

1526
EP/s/ 5729

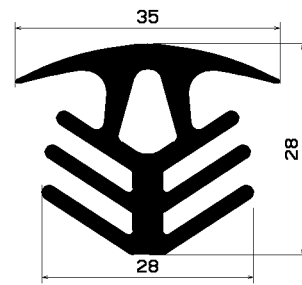

1559
EP/s/ 4888

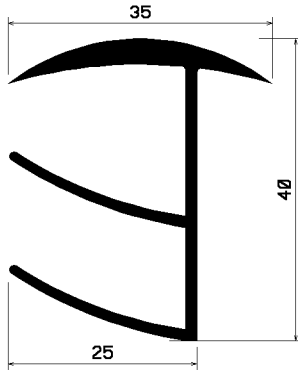

FA1560
/s/ 4998

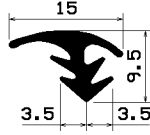

1675
EP/s/ 5726

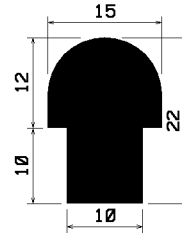

1701
Si/V/ 5776

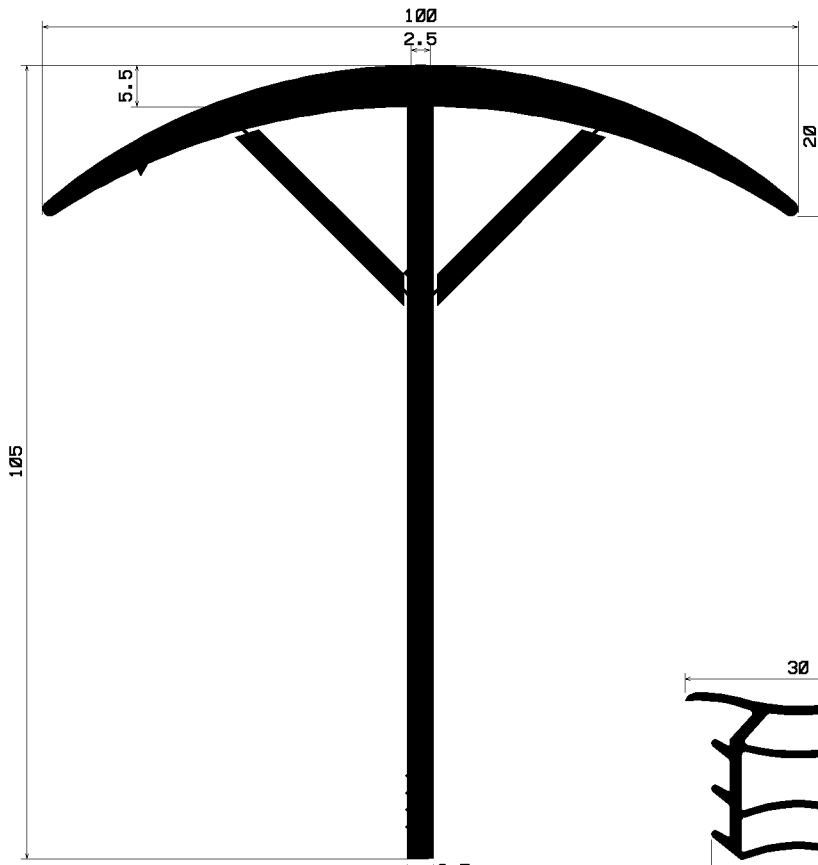

1711
EP/s/ 5860

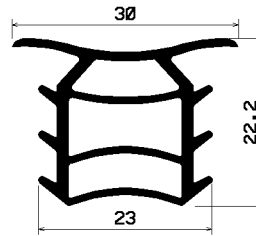

1717
EP/s/ 5859

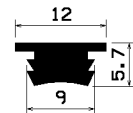

1742
Si/V/ 5967

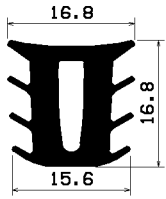

1829
EP/s/ 6204

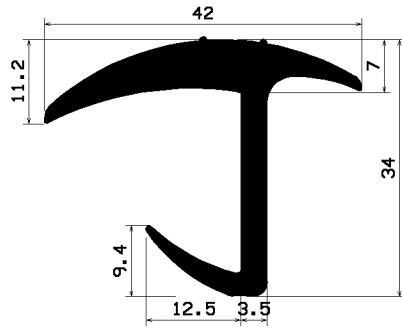

1945
EP/s/ 6840

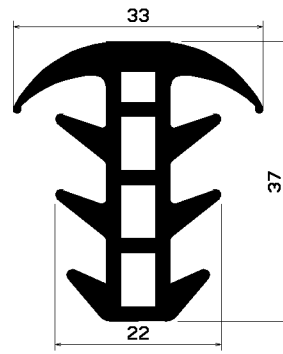

1982
EP/s/ 6936

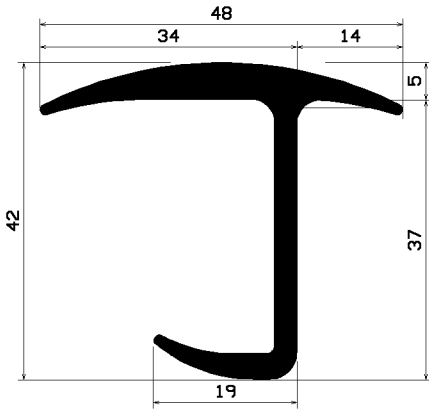

2050
EP/s/ 7115

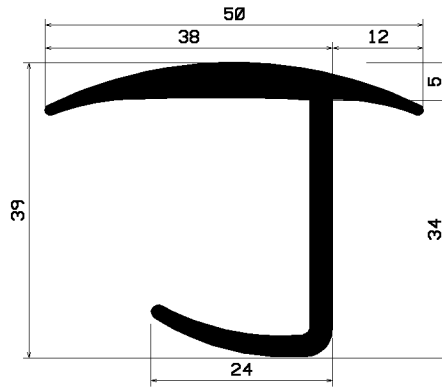

2051
EP/s/ 7116

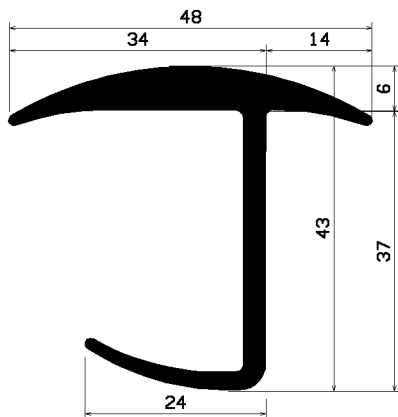

2052
EP/s/ 7117

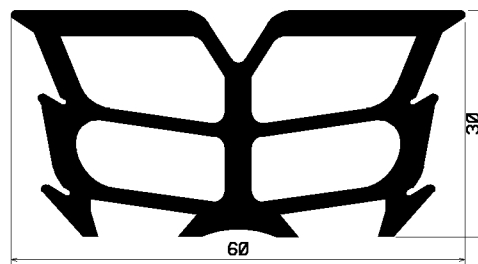

2068
EP/s/ 7167

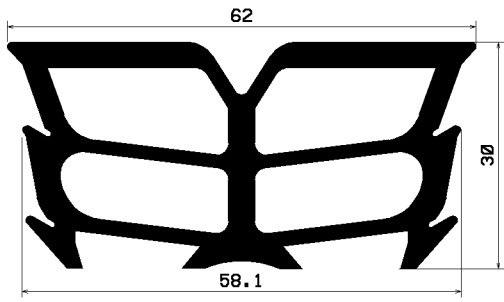

2087
EP/s/ 7241

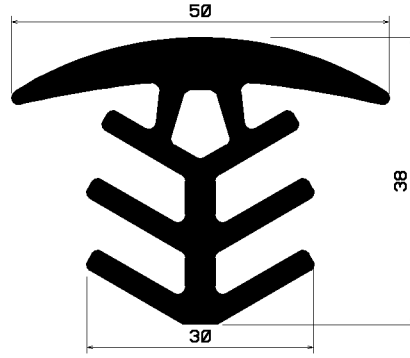

2102
EP/s/ 7271

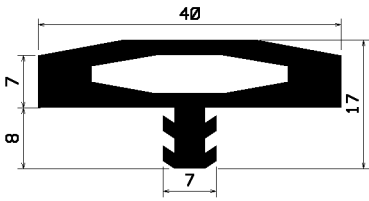

2114
Si/I/ 7303

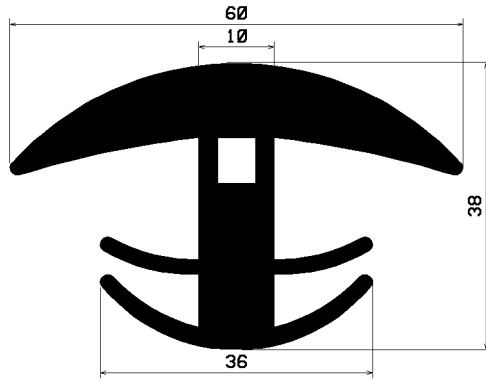

2169
EP/s/ 7621

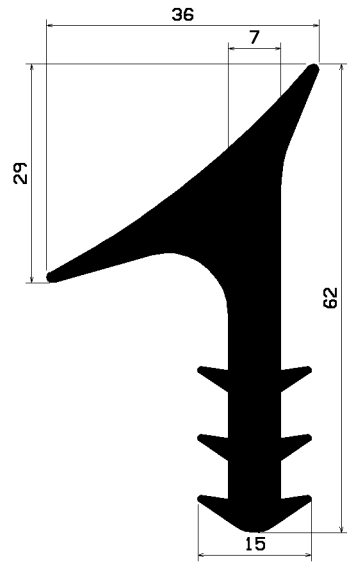

2247
EP/s/ 7851

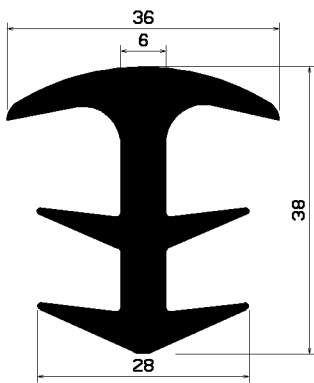

2285
EP/s/ 7980

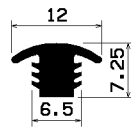

2300
EP/s/ 8065

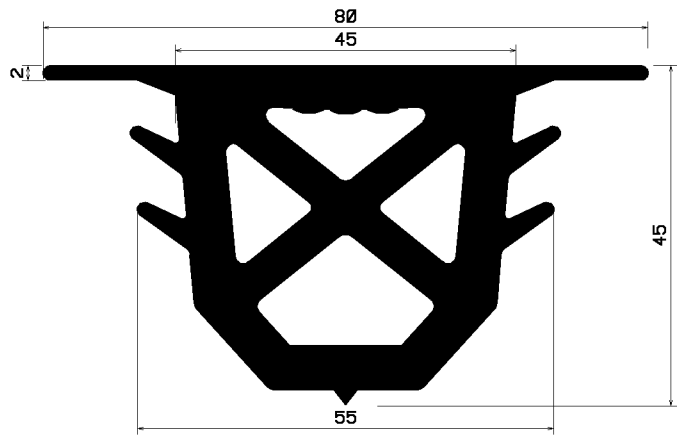

2328
EP/s/ xxxx

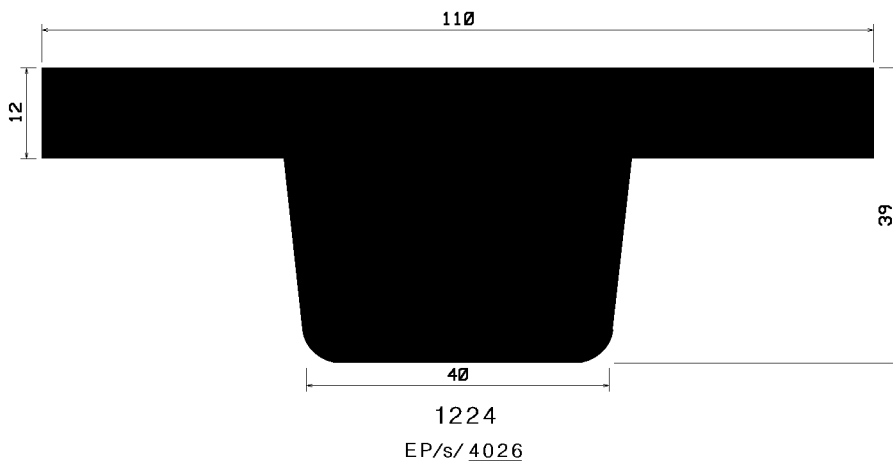
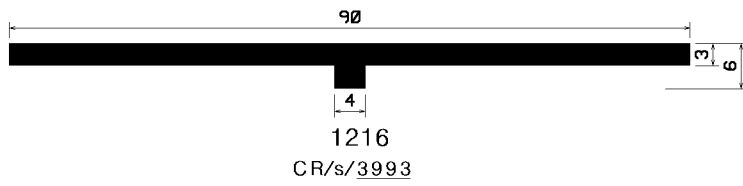
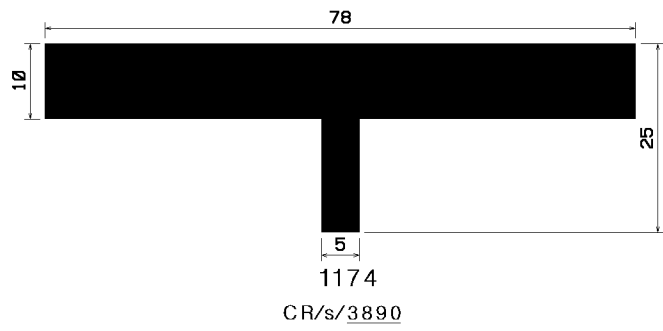
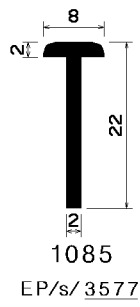
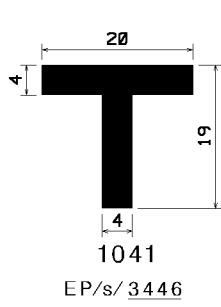
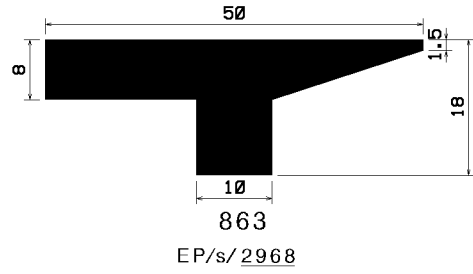
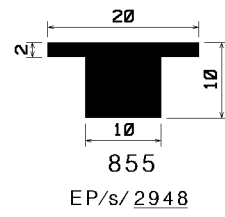
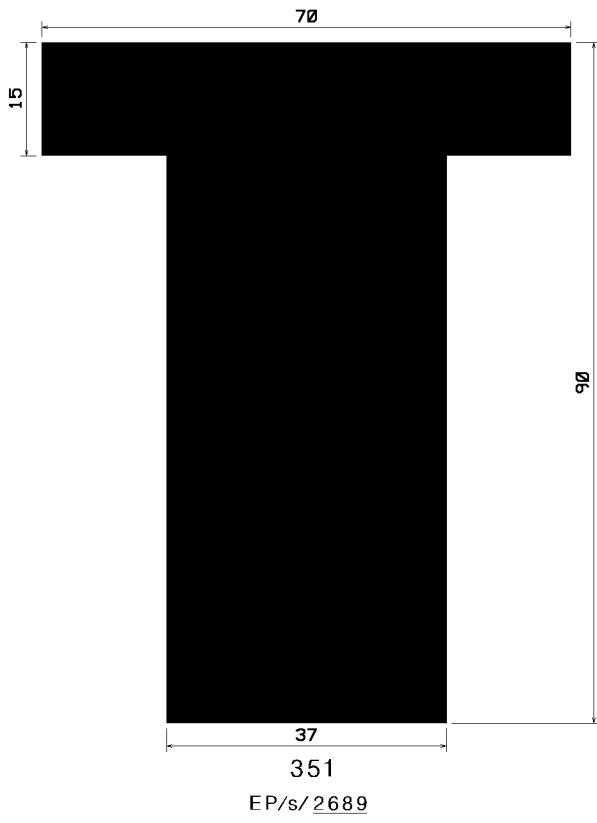

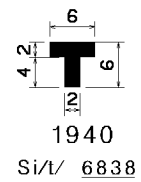
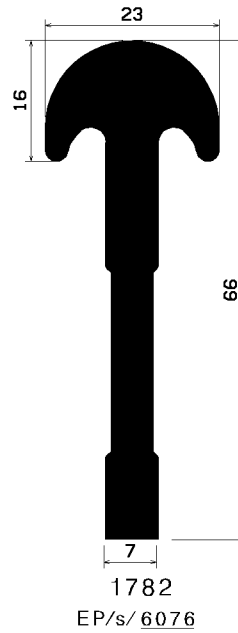
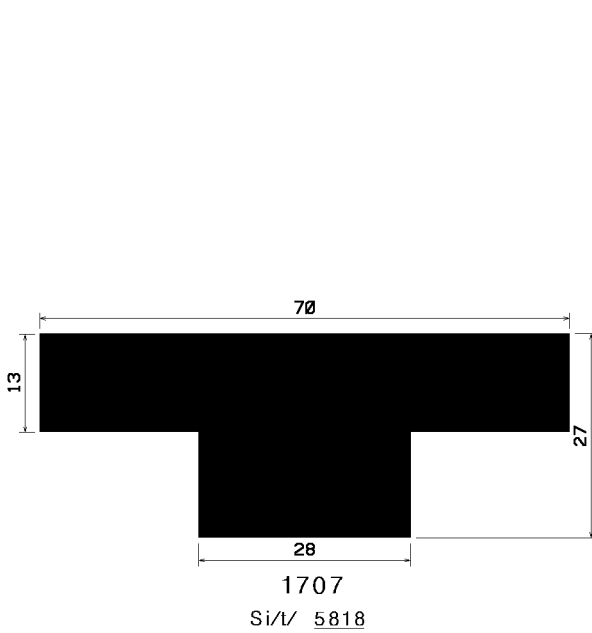
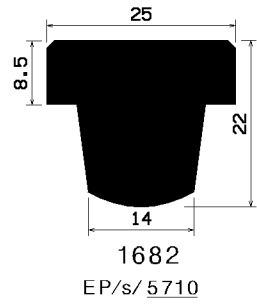
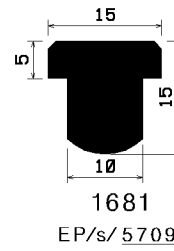
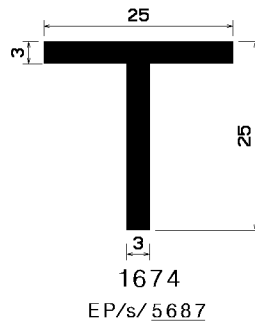
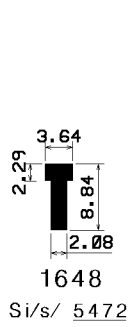
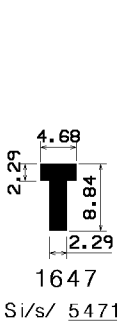
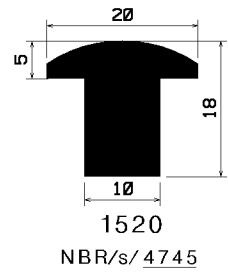
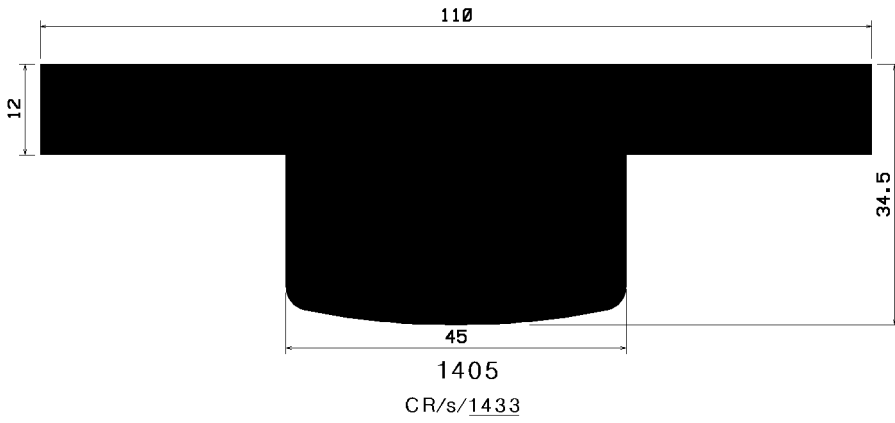
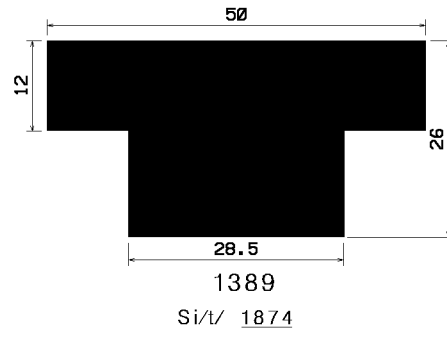
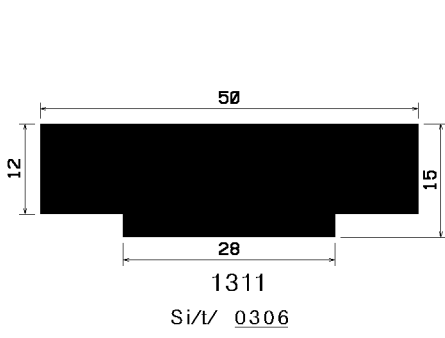

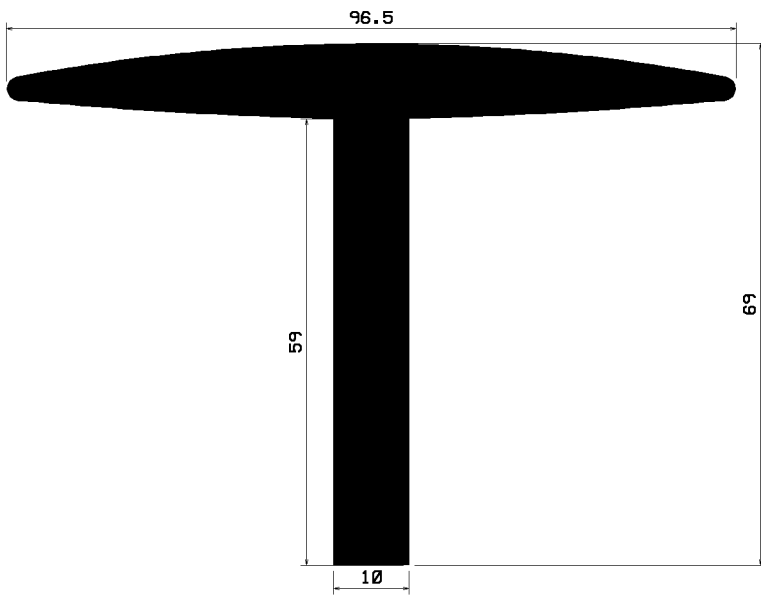

1970
EP/s/6876

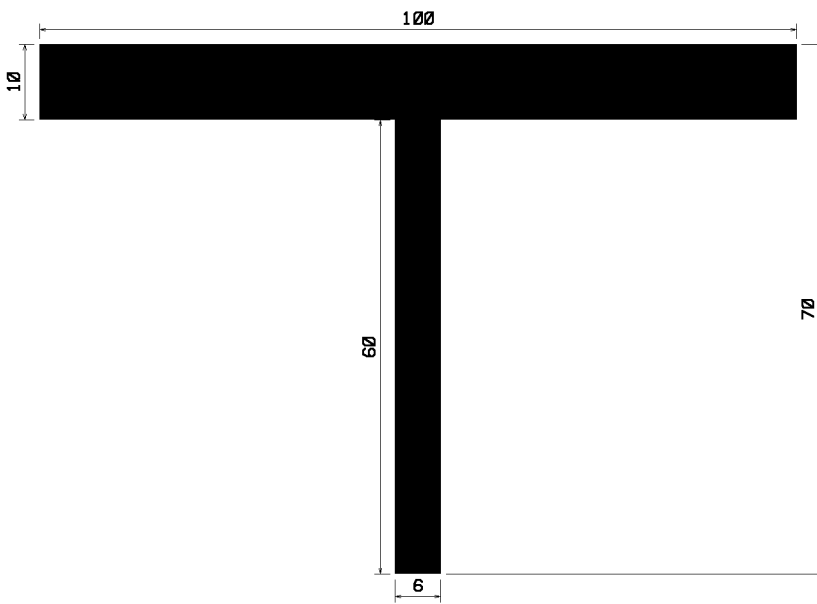

1981
EP/s/6932

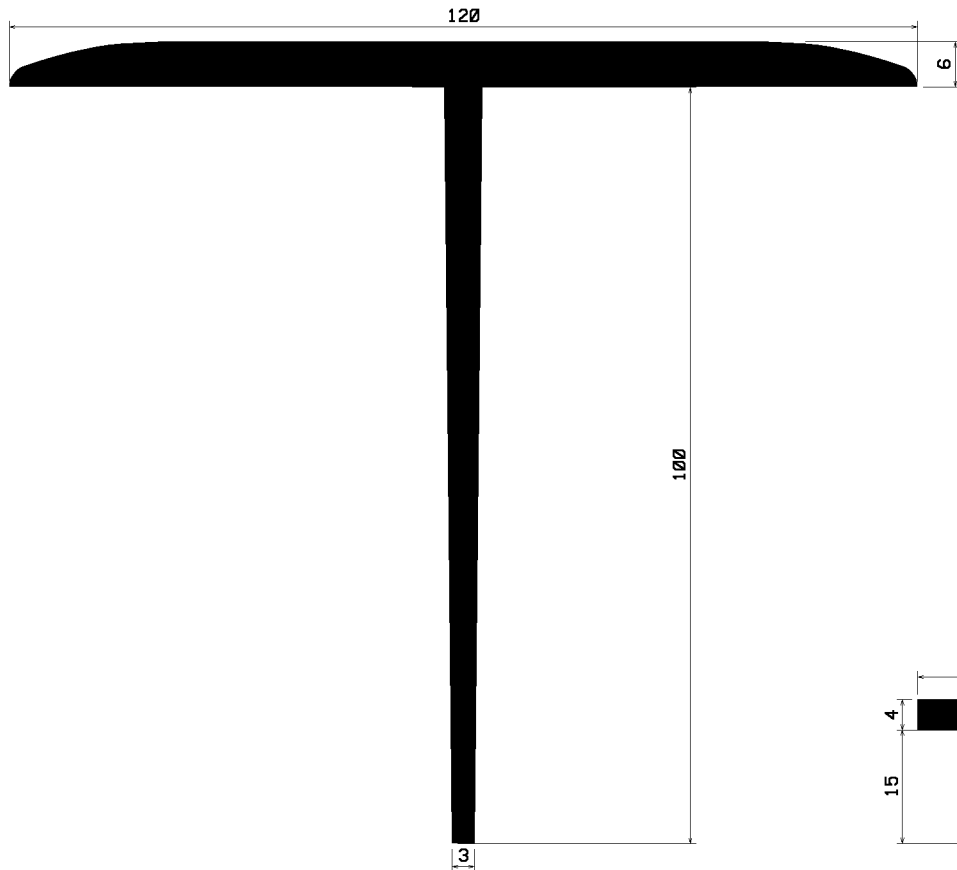

2100
EP/s/ 7267

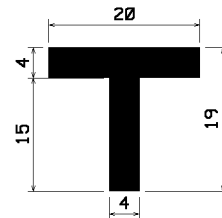

2257
EP/s/ 7899

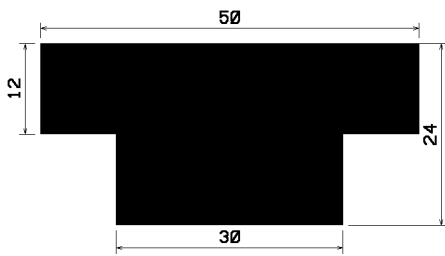

2353
EP/s/ 8154